

**CarEcology: New Technological and Ecological Standards  
in Automotive Engineering**

**Module 3. Alternative Drive Systems**

***9. Implementation of hybrid cars:***

***Honda Civic Hybrid IMA-system***

Name of author(s): Raf Catthoor, Freek Beeckman

*Departement IWT  
Karel de Grote-Hogeschool  
Antwerp - Belgium*

## Case Study: Honda Civic Hybrid IMA-system



### Table of contents

1.	The IMA-system.....	3
1.1	Concept .....	3
1.2	Powertrain configuration .....	4
1.3	Drive-by-wire.....	5
2.	The Engine .....	5
3.	The Electric Motor .....	6
4.	The Intelligent Power Unit.....	8
5.	The Motor Control Module .....	10
6.	The Motor Power Inverter .....	11
7.	The DC-DC Converter .....	14
8.	The Battery Pack.....	15
9.	Working modes of the IMA-system .....	16
9.1	Starting.....	16
9.2	Motor assist.....	17
9.3	Regeneration .....	18
9.4	Auto Stop .....	18
10.	Honda hybrids overview.....	19



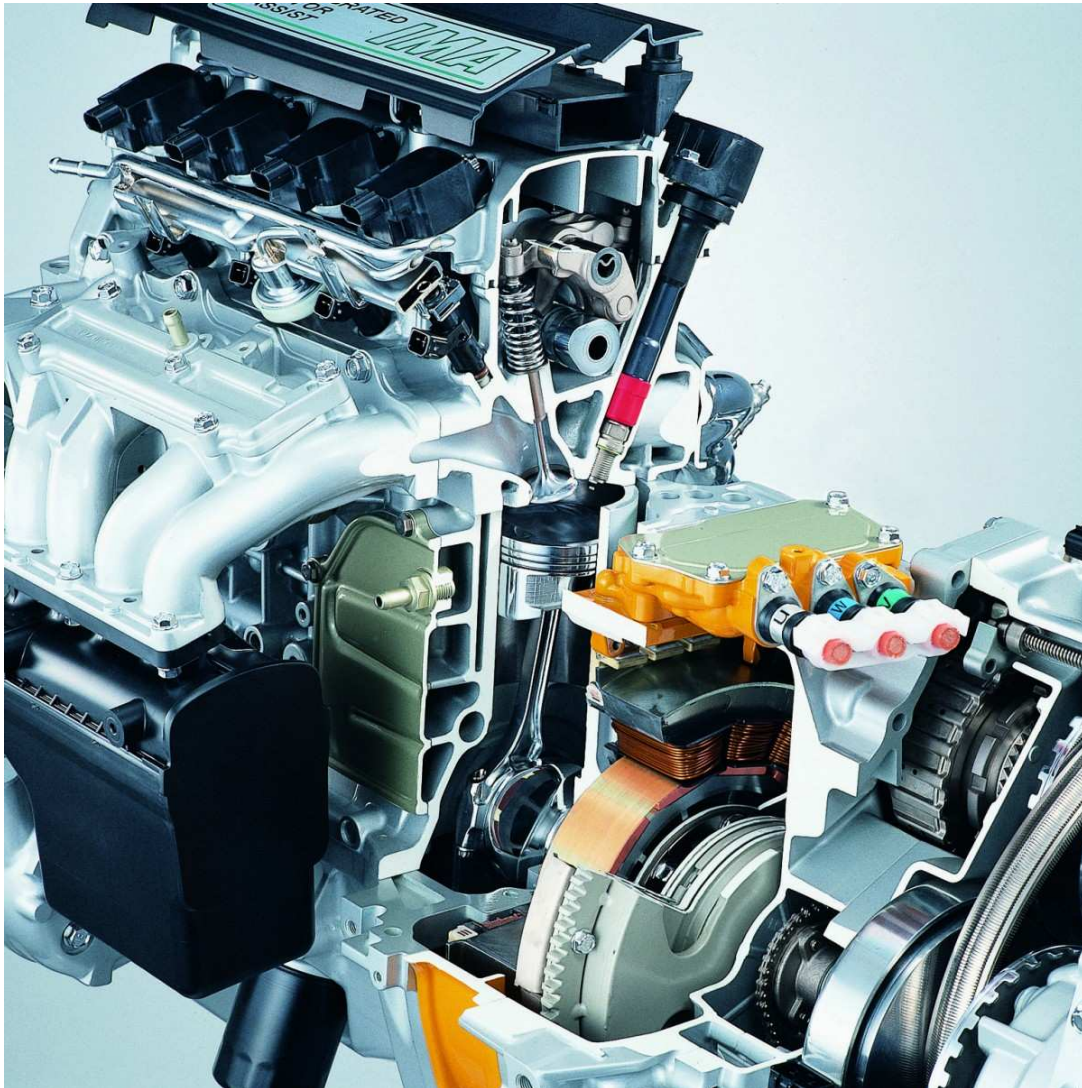

*Honda IMA engine (left), motor (middle) and Continuous Variable Transmission*

The Intelligent Power Unit (IPU) is located behind the rear seat and comprises all high voltage parts: the nickel-metal hydride (Ni-MH) battery pack, the inverter and the DC-DC converter. The electric motor and the IPU are connected by means of a 3-phase power cable installed in an aluminium duct under the floor.

### **1.2 Powertrain configuration**

All Honda IMA-systems use the same *parallel hybrid powertrain system*. Both the engine and the electric motor generate power to drive the wheels. The addition of computer controls and a transmission allow these components to work together, which results in a higher efficiency than a series configuration. The latter has several conversions of mechanical power in electricity and back.

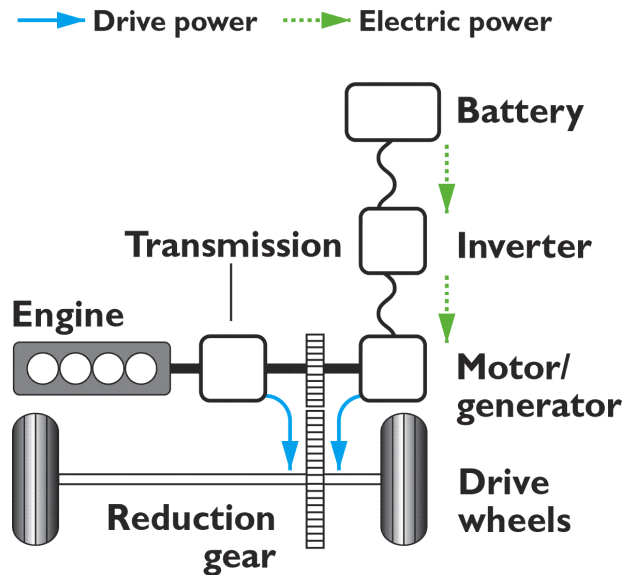

### 1.3 Drive-by-wire

The Honda Civic Hybrid has an electronic drive-by-wire system for the throttle plate. There is no direct throttle cable connection, an electric actuator moves the throttle butterfly valve in the intake system to change the actual throttle position. This system isn't reserved to hybrids, but is very practical in this type of vehicles. This way, it's possible to continuously optimise the butterfly valve position and movement speed, based on the measured throttle pedal position, speed and acceleration. As a result, the drivability increases thanks to an optimised engine responsiveness and better match to the driver's expectations. This system is an important component in Honda's i-VTEC system to help smooth switching between the different modes.

## 2. The Engine

Making an environment friendly car with low fuel consumption starts with a small, efficient and low friction engine. Honda combines an electric motor with a *petrol engine* because of two main reasons. Firstly, Honda has far more experience in petrol engines rather than in diesel engines. Secondly, all car markets apart from Western Europe mainly want petrol engines. This has the logical consequence of putting a petrol engine in the Honda hybrid vehicles.

The engine in the 2006 Civic Hybrid is a 1.3-litre four-cylinder with several advanced technologies to optimise combustion and to reduce engine friction. The valves in the cylinder are positioned in a small 30° angle for a powerful swirl in the cylinder, which stimulates an efficient combustion and permits a leaner burning. To reduce friction, a small cylinder head is applied with a single overhead camshaft (SOHC). Special plateau honing of the cylinder walls creates an ultra smooth finish and the piston skirts are impregnated with the low-friction *Molybdenum Di-Sulfide (MoS2)*. Further, the i-DSI system is used; this Intelligent Double and Sequential Ignition system uses two spark plugs per cylinder. This helps facilitate an intense and rapid combustion process in the engine. The ignition

control has eight ignition coils that are independently controlled according to a dynamic engine map program. Furthermore, the cylinder block is made from aluminium and has a new lightweight and small frame to save weight.

Honda has applied an *automatic cylinder shut off system* (Auto Stop); this turns the engine off when the vehicle stands still. This system is discussed in paragraph 9 (Working modes of the IMA-system).

The 2006 Civic Hybrid is the first Honda with the 3-Stage i-VTEC system. This system reduces engine friction when regenerative braking is applied. This is done *by idling all four cylinders*, which means that the valves in the four cylinders are deactivated, resulting in lower pumping losses. This reduces engine friction by 66 percent. Because of that, more energy can be sent to the IMA-motor. This increases the regenerated energy when regenerative braking is applied.

The following table gives the mean specifications for the Civic Hybrid engine:

Engine Type	Water-cooled in-line 4-cylinder petrol engine
Bore x Stroke (mm)	73,0 x 80,0
Displacement (cm <sup>3</sup> )	1339
Max power output (kW/hp)	70/95 @ 6000 rpm
Max torque (Nm)	123 @ 4600 rpm
Compression ratio	10,8
Emissions rating	EURO IV

### 3. The Electric Motor

The electric motor is mounted between the petrol engine and the CVT transmission. It is a lightweight 3-phase Brushless DC motor with four functions: it acts as a starter motor, an engine balancer, a dynamo and an assist traction motor. The dynamo regenerates braking energy and converts fuel energy into battery energy. When needed, the IMA-motor assists the ICE for more output power. In assist mode, the electric motor converts 96 percent of its input electricity into motive energy. So the motor has a significantly better efficiency than the petrol engine.



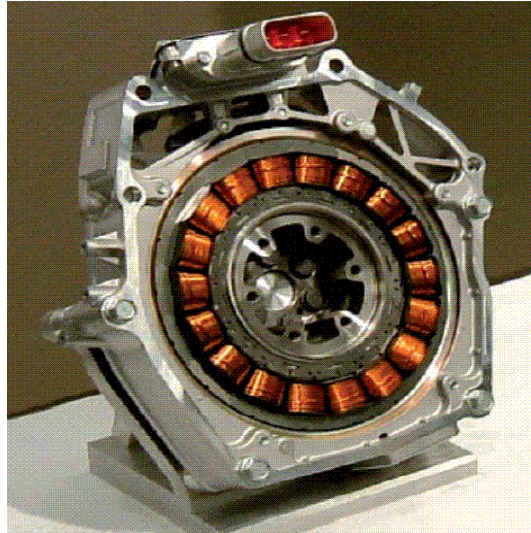

The motor itself consists of a 3-phase stator, mounted on the outside house, and a rotor mounted directly on the crankshaft of the engine. The rotor consists of 12 permanent magnets, mounted around the outside of the rotor. In the housing, three commutation sensors detect the direction of the rotor.

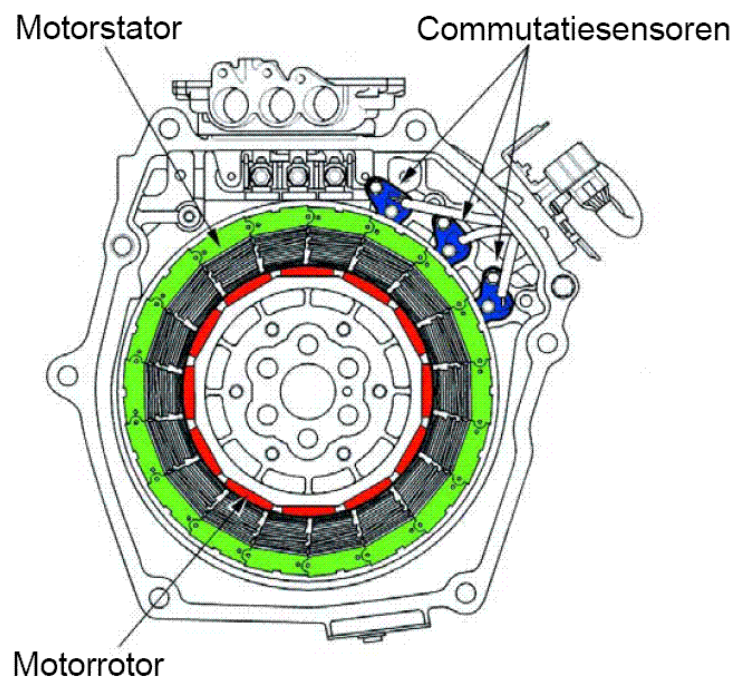

During one revolution, the current has to be switched 36 times. There are 3 phases multiplied by 12 permanent magnets, equals 36 steps per revolution. The angular resolution is then  $360^\circ$  divided by 36, equals 10 mechanical degrees per step. This means that every time the rotor has moved  $10^\circ$ , the current will be send through other coils.

This is an overview of the electric motor in the 2006 Honda Civic Hybrid:

Motor Type	Permanent Magnet DC brushless motor
Rated voltage (V)	158

	Assist	Regenerator
Max power output (kW/hp)	15/20 @ 2000 rpm	15,5/21 @ 1500-2000 rpm
Max torque (Nm)	103	123
Motor width (mm)	65	65

The CVT (Continuous Variable Transmission) is mounted next to the IMA-motor and contributes to lower fuel consumption and smooth driving. Unlike a conventional transmission with five or six gears that change the gear ratio in steps, a CVT uses a steel belt and a variable pulley to change the final drive ratio between a minimum and maximum setting of 2,526 and 0,421.

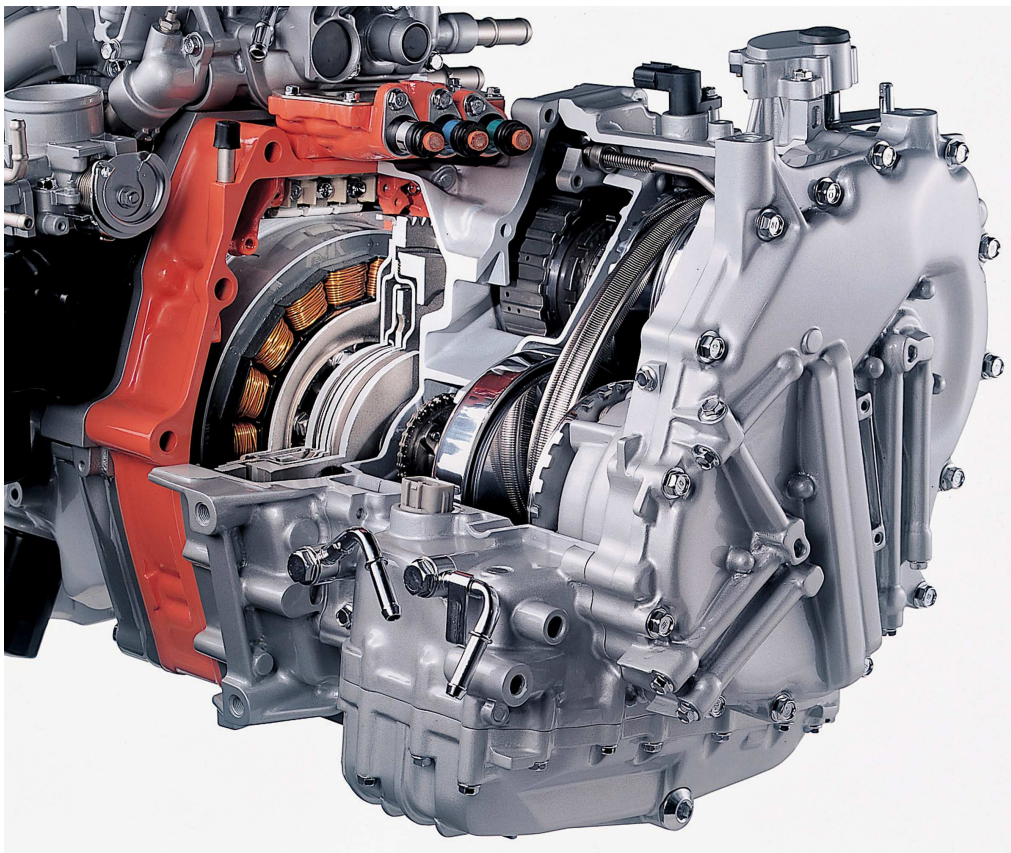

*Honda IMA Continuous Variable Transmission on the right*

#### 4. The Intelligent Power Unit

The Intelligent Power Unit (IPU) contains all high voltage parts of the IMA-system. These are the Motor Control Module (MCM) (discussed in paragraph 6), the Motor Power Inverter Assembly (MPI) (discussed in paragraph 7), the DC-DC converter (discussed in paragraph 8), the battery pack and the connection card (discussed in paragraph 9) and the ventilator of the Motor Power Control module (MPC). The following scheme gives an overview of the situation.



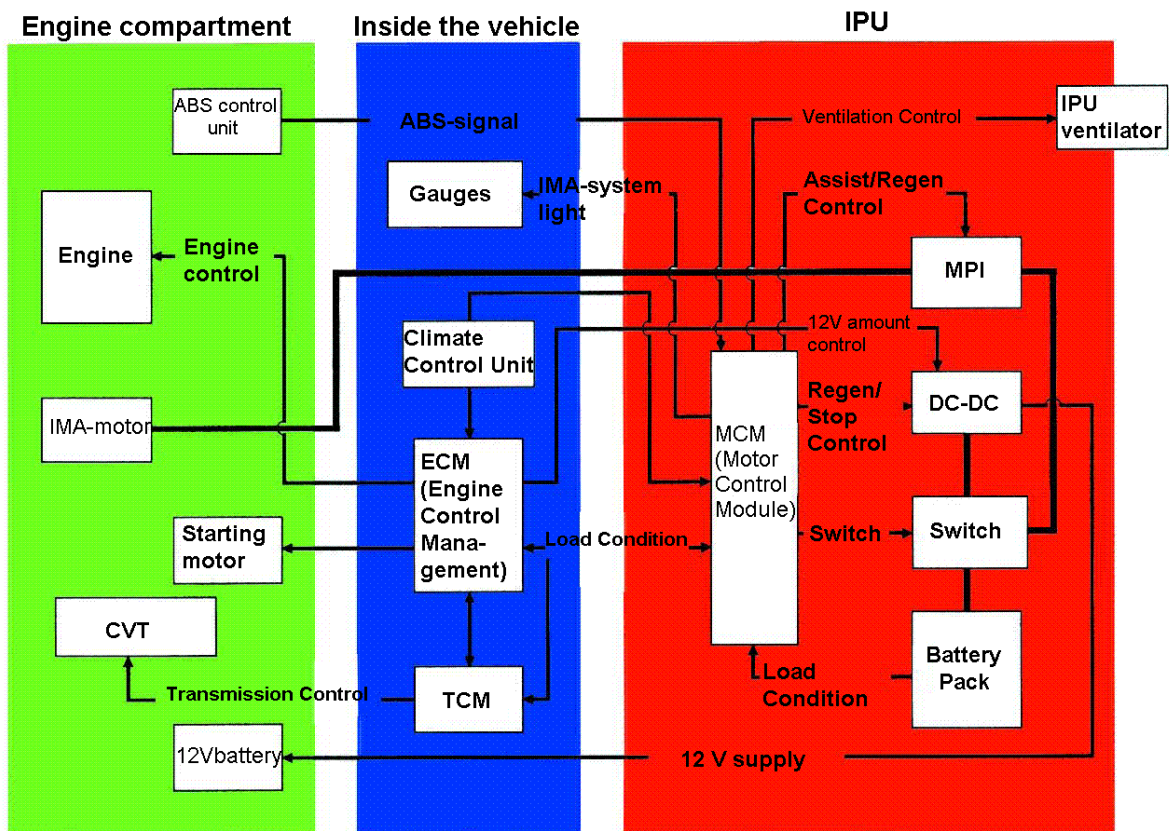

The total IMA system consists of three subsystems; the high voltage IMA system (red), the load system (green) and the control system (blue). These three systems and their connections are given in the figure below.

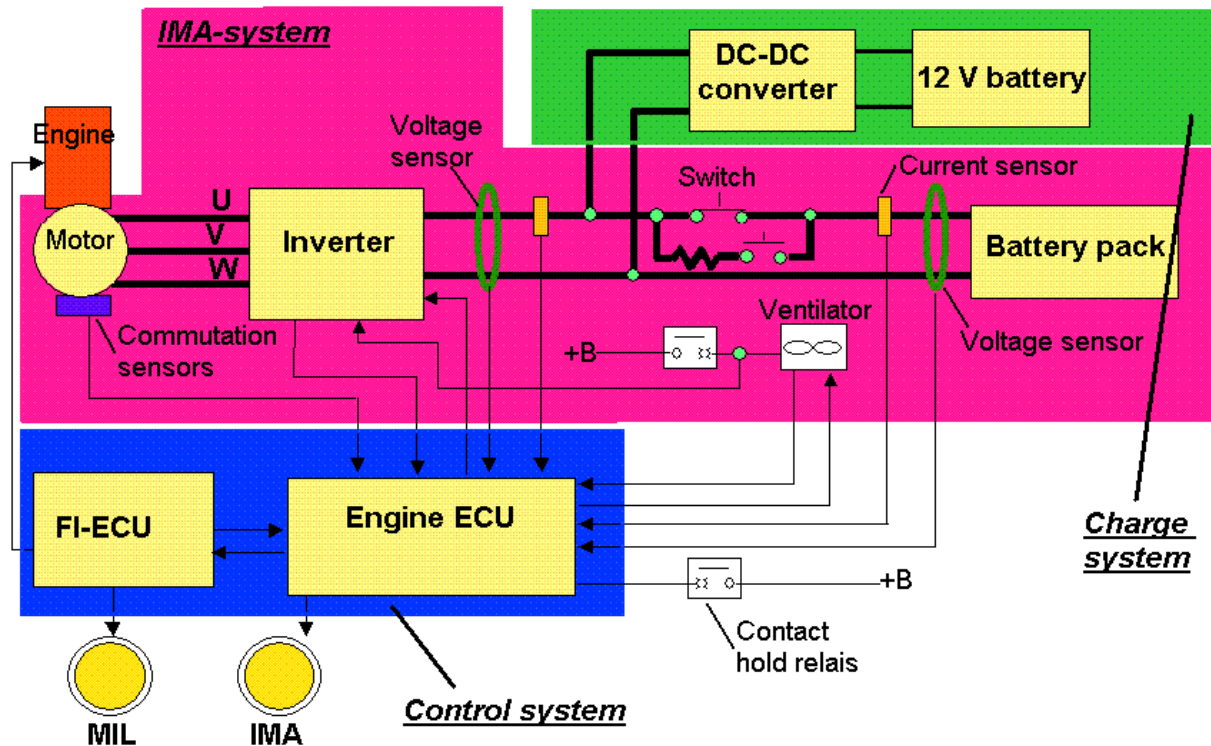

The inverter converts the DC battery voltage into a three-phase voltage for the BLDC motor, and the other way round during energy regeneration. The 165 Volt bus (between battery pack and the inverter) has a voltage sensor, a mean switch and a current sensor. A DC-DC converter feeds the traditional 12 voltage battery.

All components and sensors send signals to the engine ECU in the control system. This control system reports malfunctions to the driver via a MIL (Malfunction Indicator Light) and information about the IMA-system via the IMA dashboard light.

## 5. The Motor Control Module

The Motor Control Module (MCM) is the central part in the Intelligent Power Unit. It controls the Motor Power Inverter module (MPI) and does the battery management for the battery pack. Furthermore, the MCM has a self diagnostic function and takes care of the communication with external diagnostic tools.

To fulfil these important functions, it receives a number of input signals:

- Torque requests
- ABS control signals
- U, V and W-phase motor and Motor Power Inverter current sensor signals
- Battery pack voltage and current signals
- Commutation signals
- Working signal of the cooling ventilator

- Temperature signals from the DC-DC converters, the battery cells and the inverter
- Error code signals

And the MCM-module sends output signals to:

- The inverter
- The high voltage and the circulation switch
- The IMA-system light and the IMA malfunction indicator light
- The ventilator of the MPI-module
- Load condition of the battery pack
- The two contact-hold relays
- The DC-DC converter
- External diagnostics tools

Based on the information the MCM receives, and thus from the condition of the vehicle, it regulates the degree of assistance from the electric motor as well as the amount of regenerative energy from the engine. The regulation of the electric motor is based on the torque requests, via the inverter. In addition, the MCM also calculates the load condition of the battery pack and regulates the ventilator for the cooling.

## 6. The Motor Power Inverter

The Motor Power Inverter module (MPI) inverts the 158 V-DC from the battery pack into threephase AC voltage for the electric motor. The MPI-module consists of two parts: a driver unit and an IGBT bridge circuit. The driver unit drives the six IGBT's based on the signals from the Motor Control Module (MCM).

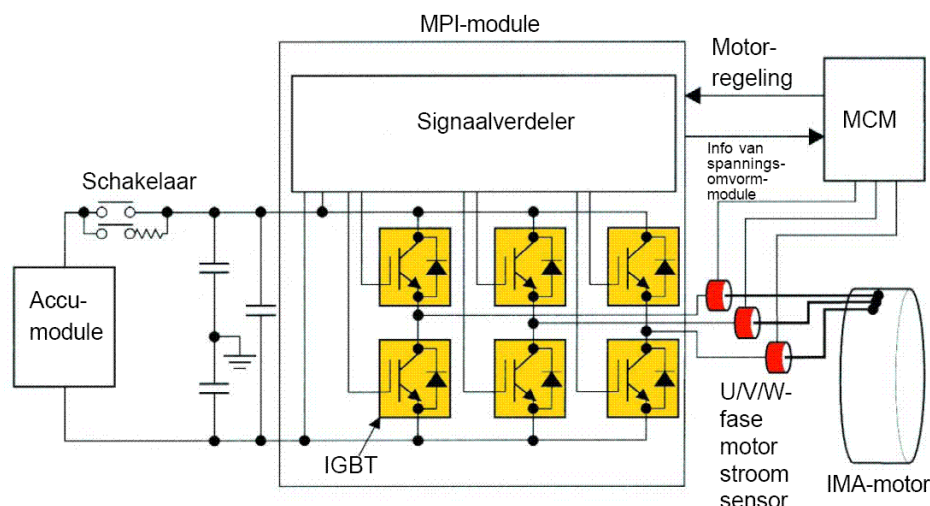

The actual rotor position is measured by the three commutation sensors on the IMA-motor. These three sensors output signals A, B and C are sent to the Motor Control Module. Based on the input

from these sensors, the Motor Control Module generates the corresponding programmed output value for U<sub>l</sub>, V<sub>l</sub>, W<sub>l</sub>, U<sub>h</sub>, V<sub>h</sub> and W<sub>h</sub>. (l = low and h = high) to the Motor Power Inverter.

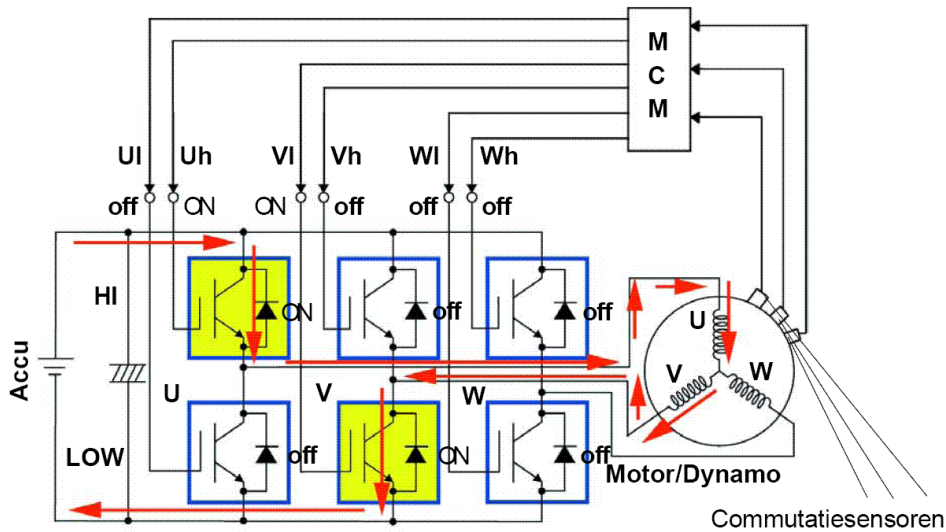

In the first commutation step the generated signals by the commutation sensors are: A = low, B = low and C = high. Based on this information, the Motor Control Module knows that the motor is positioned within the first 10 degrees of the mechanical position. The output signals for this position are U<sub>h</sub> and V<sub>l</sub> high, and V<sub>h</sub>, W<sub>h</sub>, U<sub>l</sub> and W<sub>l</sub> low.

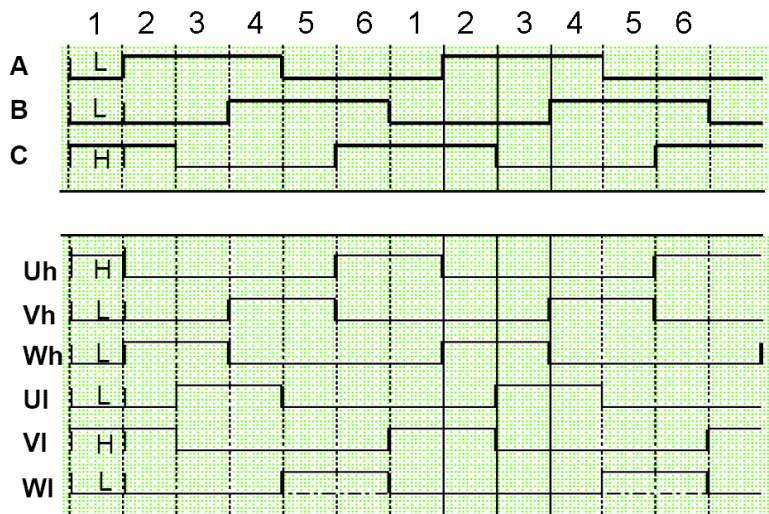

The next figure gives an overview of all commutation steps (traction mode).

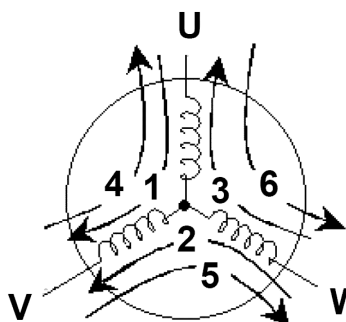

Commutation step	Active coil pair	IGBT high/IGBT low
1	U ---> V	U Hi ---> V Lo
2	W ---> V	W Hi ---> V Lo
3	W ---> U	W Hi ---> U Lo
4	V ---> U	V Hi ---> U Lo
5	V ---> W	V Hi ---> W Lo
6	U ---> W	U Hi ---> W Lo



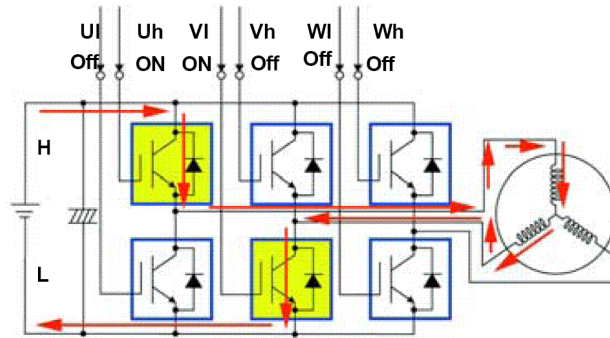

Commutation step 1

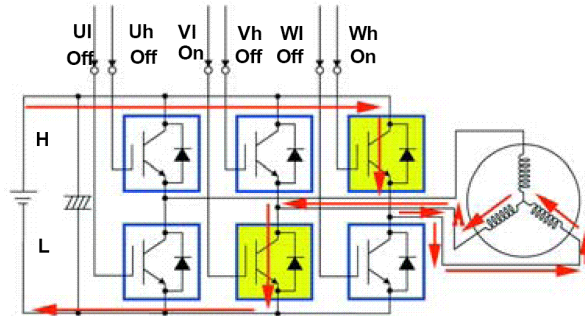

Commutation step 2

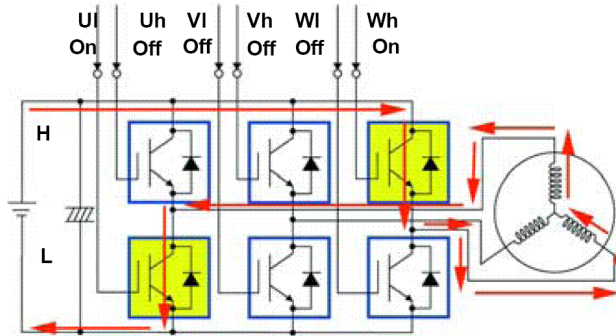

Commutation step 3

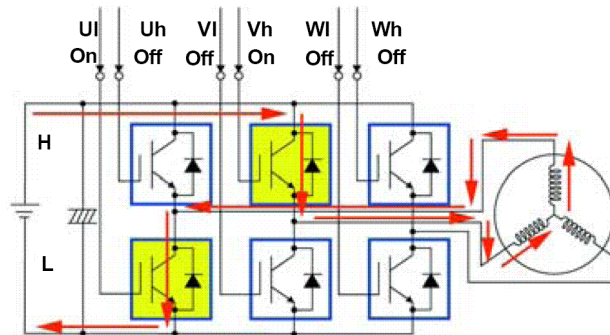

Commutation step 4



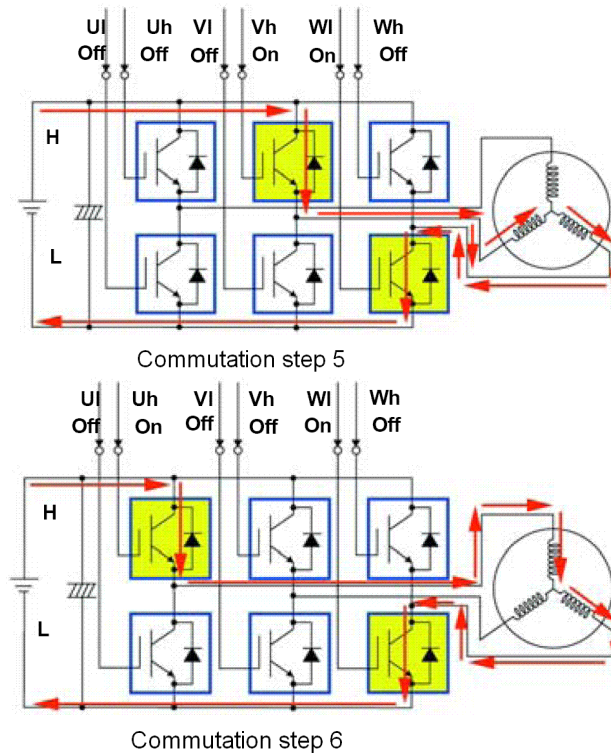

During regenerative braking, the DC current flows in the opposite direction, through the diodes instead of through the IGBT's. The figure below visualises this for the first commutation step.

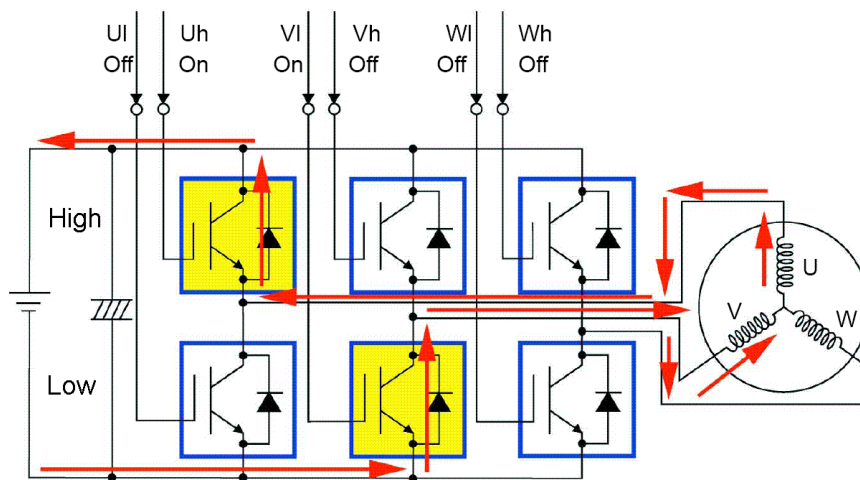

To remove the heat generated by the IGBT's, the MPI-module is ventilated. A temperature sensor is build in the inverter which sends temperature information to the MCM-module.

## 7. The DC-DC Converter

This converter supplies current to the 12V lead acid battery and the traditional electrical circuit of the car. It converts the input 158 V DC from the battery pack to 12V DC.

The Motor Control Module (MCM) controls the level of DC produced by the DC-DC converter, based on the actual amount of consumed current. If necessary, the Motor Control Module can switch the DC-DC converter off, for example when the load condition of the battery pack decreases.

The temperature of the DC-DC converter is controlled by the MCM. If the temperatures increases strongly or when an abnormal state of the incoming or outgoing voltage is detected, a malfunction indicator light is illuminated. Since the DC-DC converter generates heat, it's equipped with an air cooling system.

## 8. The Battery Pack

The battery pack is used to store regenerated energy, to deliver power to the motor when assisting the engine, and to feed the 12V circuit. Honda uses a Nickel Metal Hydride (Ni-MH) battery pack. This is the most common type in today's hybrid vehicles and is popular thanks to its relatively high power density and long lifetime in comparison to lead acid batteries. However, Ni-MH batteries are expensive, have a high self-discharge rate and a strong heat generation during overcharging.

The battery pack of the 2006 Honda Civic Hybrid has the following specifications:

Manufacturer	Panasonic EV Energy
Type	Ni-MH (Nickel Metal Hydride)
Number of cells	132
Capacity (Ah)	5,5
Cell Voltage (V)	1,2
Cell internal resistance (mΩ)	2,1
Cell weight (kg)	0,166
Cells per module	6
Number of modules	22 connected in series
Battery pack voltage (V)	158,4
Assist power (kW)	16,1
Regeneration power (kW)	13,3

The switch of the battery pack, the other switches, the fuses, the current sensors and other similar parts are located on the connection card. This card is connected to the battery pack for a central high voltage circuit. See the figure below:

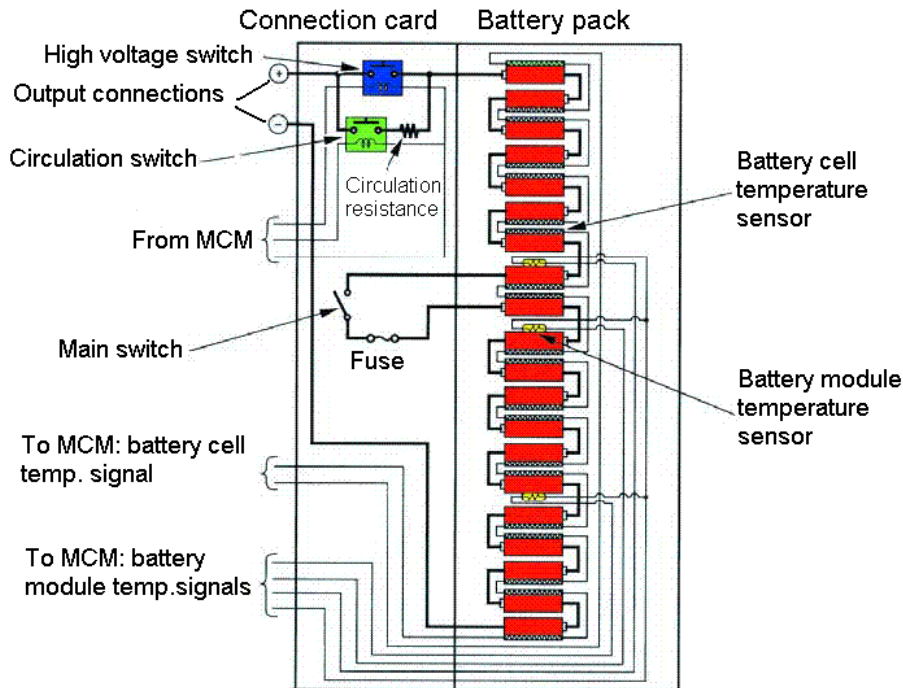

The main switch of the battery pack is located on a way it can easily be turned off during maintenance or control of the IMA-system. The circulation switch and the high voltage switch are connected in parallel with the + output of the battery pack. These switches are regulated by the Motor Control Module and are responsible for the on- and off-switching of the high voltage battery circuit. If contact has been made, the circulation switch will close first, followed by the high voltage switch. Because of this, there will be a small amount of current in the beginning and this will reduce the current peak during start-up. This protects the system.

## 9. Working modes of the IMA-system

Now that all components have been described and their function in the IMA-system has been explained, the different working modes of the IMA-system will be discussed. The 4 main modes are: starting the engine, the motor assist, regeneration and auto stop.

### 9.1 Starting

The IMA-motor functions as a starting motor to the engine. This can be either when the vehicle is started or restarted after the engine has been shut off automatically. Because the motor is mounted directly on the crankshaft from the engine, starting can be done more smoothly and quietly than with a conventional starting motor. Sometimes the motor is unable to deliver power because of low temperature, an insufficient voltage level or a failure in the IMA-system. In that case, the engine is started by means of the 12V starting motor.

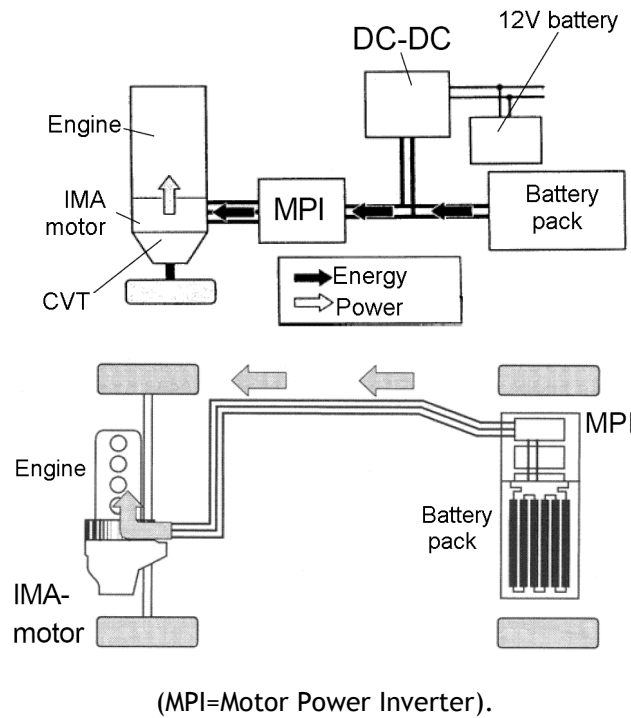

**9.2 Motor assist**

In situations of a high mechanical load (fast accelerating or climbing hills) the electric motor assists the engine with a maximum torque of 103 Nm. The Engine Control Module regulates the level of assistance, so that the state of charge of the battery stays constant within a certain range. When the battery SoC goes down to the lower limit of 25 percent, the Engine Control Module cuts off the assistance in order to prevent excessive discharge. The IMA-motor then functions as a dynamo and charges the battery pack, even if the vehicle is accelerating or if the engine runs stationary.

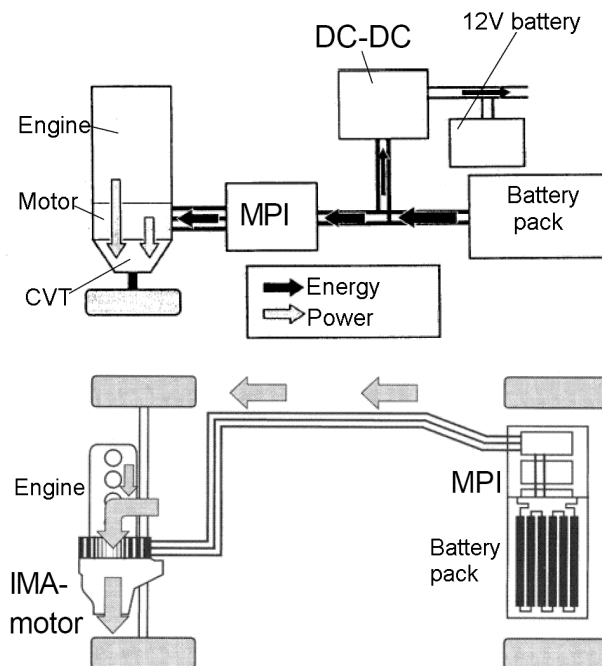

### 9.3 Regeneration

This is the regenerative braking, the electric motor builds up a resistance and slows down the car, while sending energy to the battery. The regenerative braking system is optimised by the VTEC cylinder idling system in the engine, disengaging the crankshaft. In practice, regeneration continues until engine speed drops to about 1000 rpm or when the transmission is shifted into neutral.

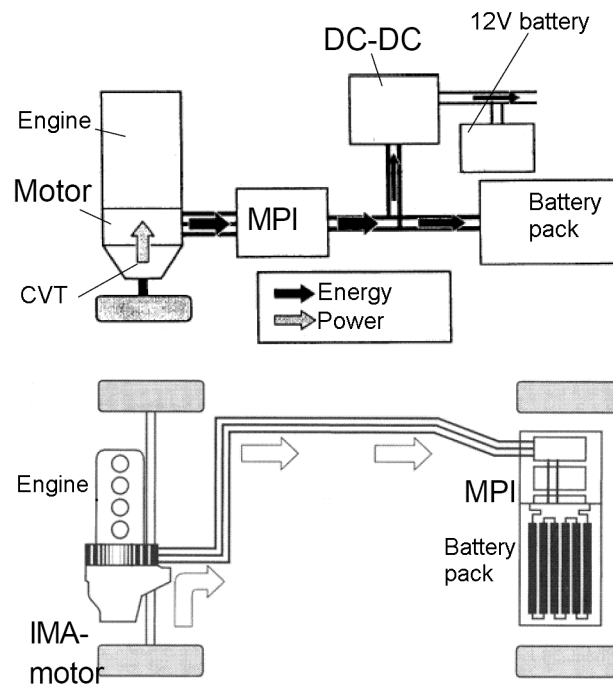

### 9.4 Auto Stop

This system turns off the engine automatically when the following requirements are fulfilled. This results in reduced fuel consumption and lowered emissions:

- Transmission in 'D'
- An acceleration above 16 km/h followed by braking until the speed is lower than 8 km/h.
- Throttle plate closed.
- Engine has reached the working temperature.
- CVT temperature is higher than 10°C.
- State of charge of the battery pack is above 25 percent.
- 'Econ mode' has been selected or air conditioning is switched off.



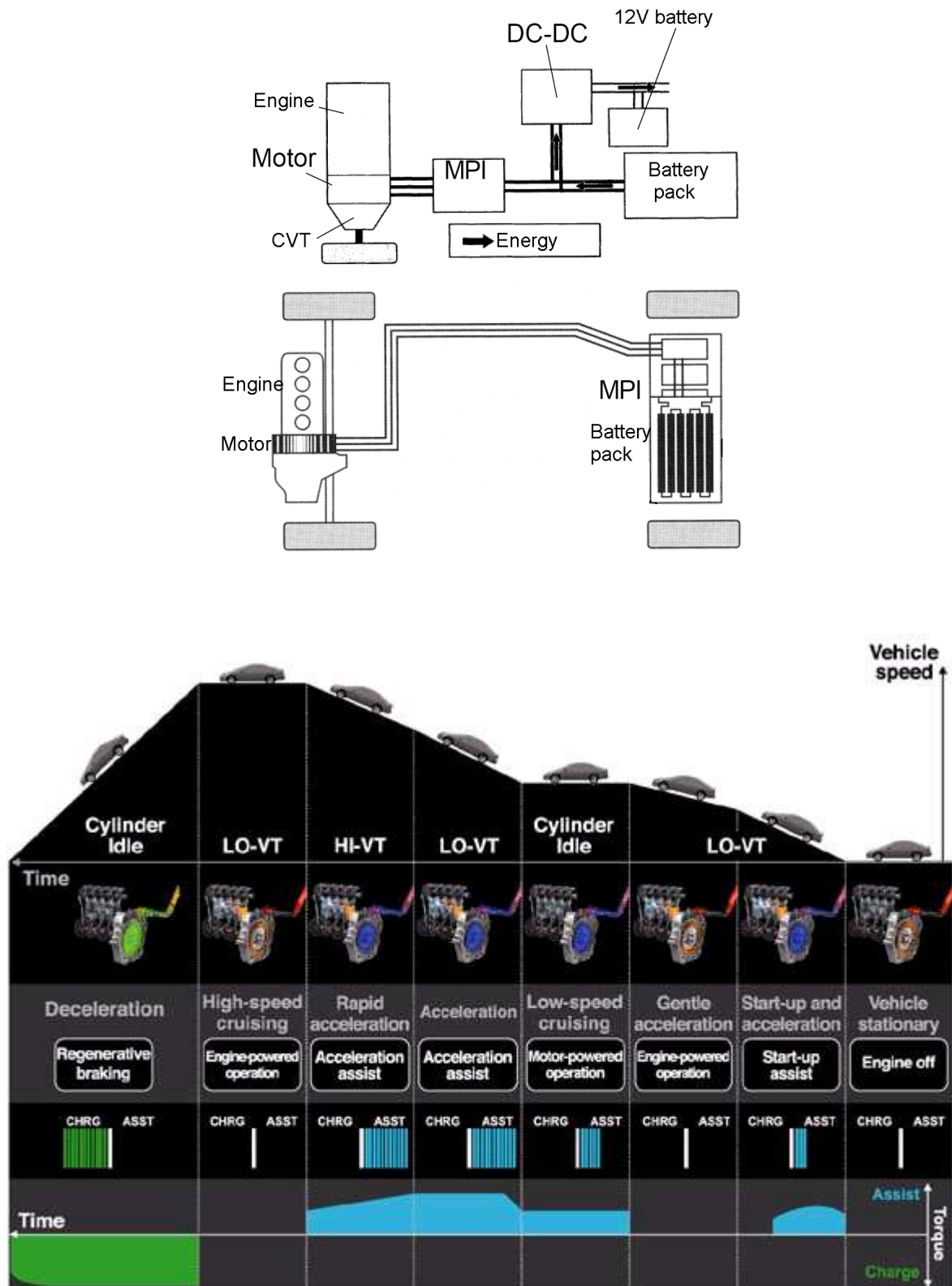

### 10. Honda hybrids overview

As mentioned in the first paragraph, the 2006 Civic Hybrid is the fourth hybrid model launched by Honda (Insight and Accord: not in Europe). The table below gives a survey of Honda hybrids.

Hybrid model	Insight	Civic	Accord	Civic
Introduction year	1999	2002	2004	2006
Engine capacity	995 cm <sup>3</sup>	1 339 cm <sup>3</sup>	2 997 cm <sup>3</sup>	1 339 cm <sup>3</sup>
Engine cylinders	3	4	6	4
Engine power	67 hp	83 hp	240 hp	95 hp
Engine torque	90 Nm	118 Nm	286 Nm	123 Nm
Motor power	13,4 hp	13,4 hp	16 hp	20 hp
Motor torque	103 Nm	103 Nm	135 Nm	103 Nm
Combined power	76 hp	90 hp	255 hp	115 hp
Combined torque	123 Nm	157 Nm	315 Nm	167 Nm
Battery type	Ni-MH	Ni-MH	Ni-MH	Ni-MH
Battery voltage	144 V	144 V	144 V	158 V
Battery capacity	6,5 Ah	6,0 Ah	6,0 Ah	5,5 Ah
Combined fuel consumption	3,4 l/100km	4,9 l/100km	7,0 l/100km	4,6 l/100km
CO2 emission	80 g/km	116 g/km	170 g/km	109 g/km